

1. číslo změny 2. číslo změny		Platí od 5. února 2018 9. dubna 2018		Opravil KANGO KANGO		Číslo změny Platí od Opravil		<b>VYSVĚTLIVKY KE SLoupCm 1 a 4</b> Vrh - výřez H: Akr - hradlo, automatické hradlo H: - hradlo Ob: - obojstranná vl - vlečka n - nákladová nz - nákladová a zastávka z - zastávka z1 - zastávka s jednovozovým nástupem na vlečkových tratích z2 - zastávka s jednovozovým nástupem ve středech, kdy odjezdí při nástupu a výjezdu přechodný doprovod koleje, na vozovkách tratí a zastávkách s jednovozovým nástupem vyprázdnění vozu výjezdu vozů z3 - zastávka provozovaná podle přílohy 520C D3 z4 - sídlo dirigovalního dispečera na tratích D3		<b>VYSVĚTLIVKY KE SLoupCm 2</b> Druh tratěvého zabezpečovacího zařízení (ve směru potaz): - - - - - = manuálně obsluhovaná - - - - - = automatický blok - - - - - = automatický blok (včetně automatického hradla) - - - - - = automatické bloky a koleje, na nichž jsou organizovány jízdy vlaků (je rezervace koleje)		<b>VLAKY OSOBNÍ DOPRAVY</b> = Ek, R, Sp } pravidelné = Os } pravidelné Vlak, který jezdí podle potřeby, jsou vyznačeny příslušným typem: S - školní		<b>VLAKY NÁKLADNÍ DOPRAVY</b> = Nac, M, M, V, M, V, M, S, S } pravidelné Vlak, který jezdí podle potřeby, jsou vyznačeny příslušným typem: S - školní		Trasy nákladních vlaků všech druhů jsou vyznačeny červeně, dále jsou uvedeny:		<b>Vyznačení dalších značek:</b> - - - - - = vlak jede po neoprávněné koleji - - - - - = vlak jede po nulu koleji nebo protisměrně směle (1) - - - - - = příhradová koleje v barveném kroužku i při jízdě nákladních vlaků jsou směřovaná příhradová ustanovení Přílohy 4 Rozkazu o zavedení ČVD (2) - - - - - = podřízená koleje zpravidla po 10 minutách více		= příjezdový den = odchodový den = zastávka jen pro výjezd = zastávka jen v obou směrech odjezdu = nezastavující zastavení vlaku s příhradovou osvětlovanou = zastavující zastavení vlaku s příhradovou osvětlovanou = výjezd dopravní služby = výjezd dopravní služby jen v některé dny = příjezdový den = odchodový den = zastávka jen pro výjezd = zastávka jen v obou směrech odjezdu = nezastavující zastavení vlaku s příhradovou osvětlovanou = zastavující zastavení vlaku s příhradovou osvětlovanou = výjezd dopravní služby = výjezd dopravní služby jen v některé dny	
----------------------------------	--	--	--	---------------------------	--	------------------------------------	--	---	--	--	--	--	--	---	--	---	--	---	--	--	--

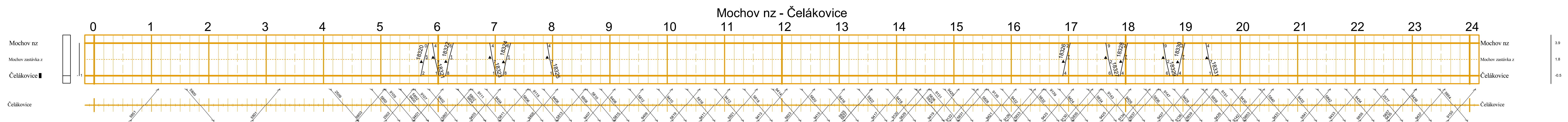

Čelákovice - Neratovice výh.č.104

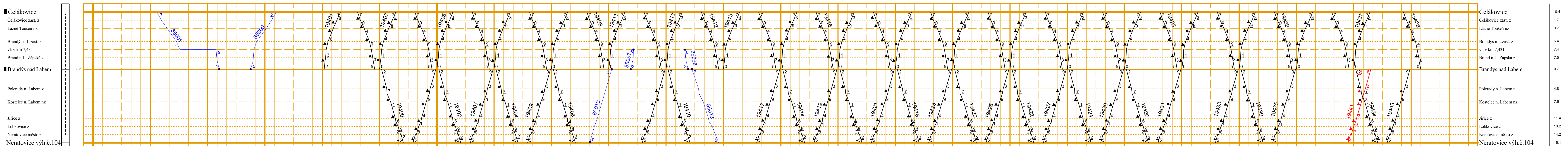

Neratovice - Kralupy nad Vltavou

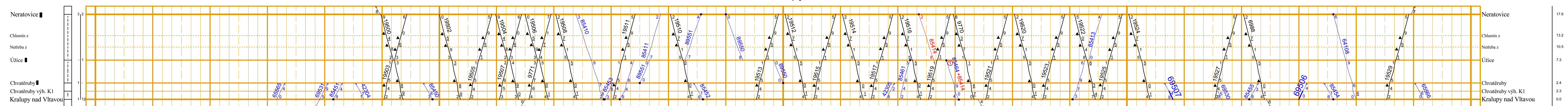

Vraňany - Libochovice

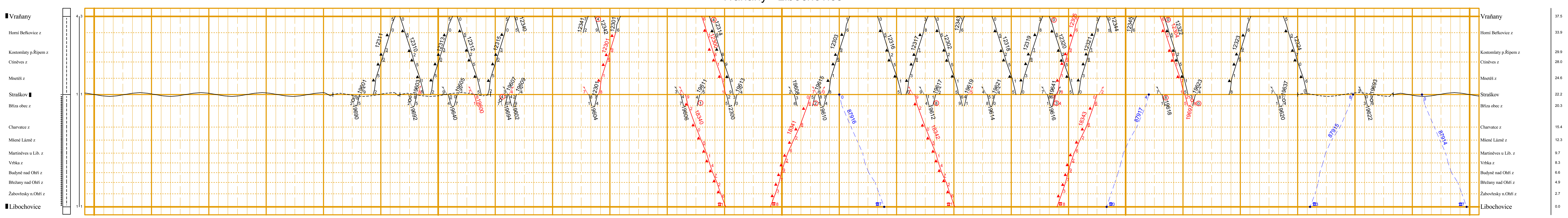

Vraňany - Lužec nad Vltavou nz

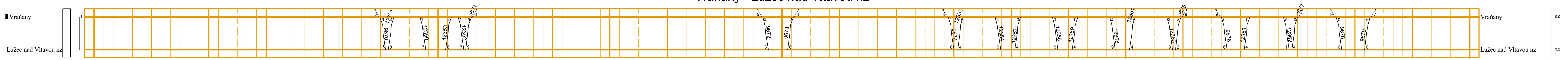

Roudnice nad Labem - Zlonice

